

TECHNICAL SPECIFICATION

TC 424X (42" x 80ft) – TRACKED CONVEYOR

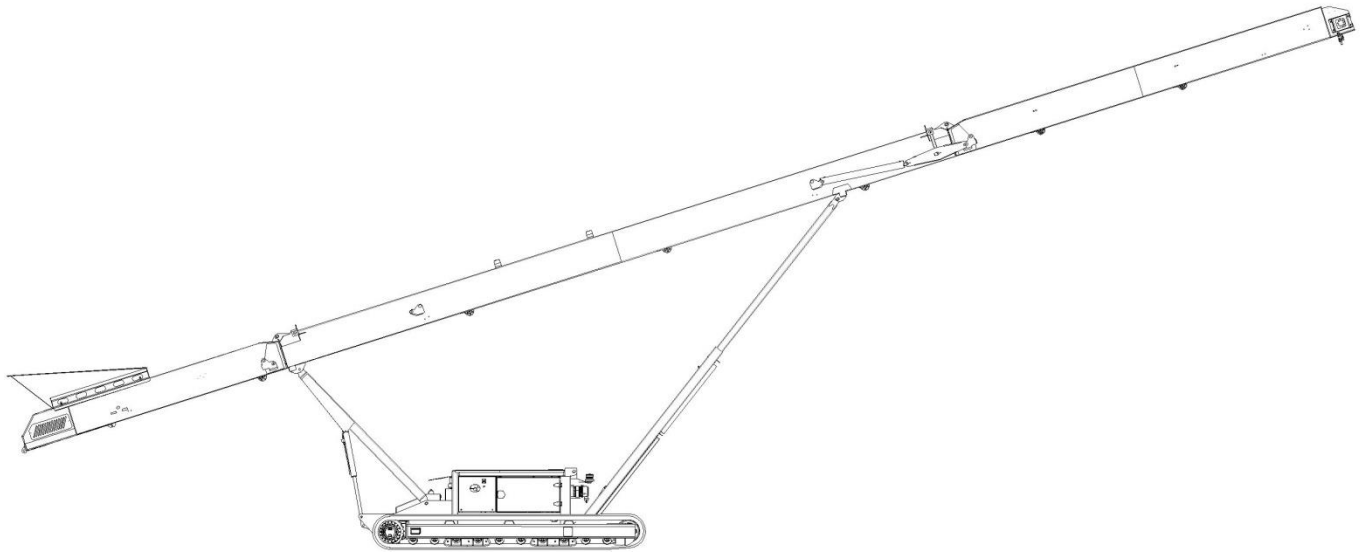

TC 424X – TRACKED CONVEYOR



The TC 424X is a track mounted fully mobile conveyor designed to work at production rates of up to 400tph. As mobile crushers and screens constantly get larger with increased throughputs, transport restrictions have not allowed for their on board conveyors to increase in size and length to cope with higher tonnages. Track conveyors fulfil this need by providing much larger stockpile capacity and at the same time improve plant mobility by removing material from the processing equipment.

TC 424X – TYPICAL APPLICATIONS

- Stockpiling from secondary crushers, screens and shredders.
- Stockpiling crushed stone, sand and gravel, mineral ores, mulch, woodchip/biomass.
- Stockpiling construction and demolition waste, top soil, coal, grain etc.
- Receiving crushed material and stockpiling safely over a quarry face/bench.
- Working as part of a mobile system on short to medium term projects.
- Ship and truck loading.

TC 424X – KEY FEATURES

- High throughput of up to 400 tph (440 Ton / hr)
- Maximum distance between tracks and head drum, for optimum stockpiling capacity
- Maximum lump feed size of up to 75mm (3")
- Front and rear adjustable telescopic to obtain desired discharge or feed in height
- Engine protection shutdown system
- Counter weight built into feed boot area to give integral strength and stability in working position.
- Folding head and tail section for ease of transport
- Paint specification, Cream: RAL 7032, Red: RAL 3001
- Options available

TC 424X – KEY ADVANTAGES

- Removes the need for a dedicated wheel loader to constantly remove material from the crusher, screen or shredder.
- Reduces fuel cost by up to 75%
- Reduces operating cost by up to 70%
- Removing / reducing loading shovel movements reducing operating cost.
- Reduces screener idle time increasing production.
- Reduces face excavator idle time increasing production.
- Production rates of up to 400tph.
- Hydraulic folding head section allowing for compact road transportation.
- Typical set up time of under 10minutes.
- Hydraulic tail section height adjustment whilst at the same time maintaining head drum height ensuring maximum stockpile capacity.
- High specification machine designed for ease of maintenance commanding an excellent resale value at project conclusion.

TC 424X – STOCKPLING CAPACITIES

All stockpiling capacities are calculated based on material, with a bulk density of 1.6 tonnes per m³ (100 lb/ft³)
Stockpile angle of repose 37°

Conical Stockpile Capacities

| Angle of Conveyor Belt (Degrees) | Stockpile Height | | Stockpile Capacity (Volume) | | Stockpile Capacity (Mass) | |
|----------------------------------|------------------|---------|-----------------------------|--------------------|---------------------------|-------|
| | (m) | (ft) | (m ³) | (yd ³) | (Tonnes) | (Ton) |
| 26° | 11 | 35' 9" | 2,455 | 3,210 | 3,927 | 4,329 |
| 24° | 10.42 | 33' 10" | 2,086 | 2,729 | 3,338 | 3,680 |
| 22° | 9.82 | 31' 11" | 1,746 | 2,284 | 2,794 | 3,080 |
| 20° | 9.22 | 29' 11" | 1,445 | 1,891 | 2,313 | 2,549 |
| 18° | 8.6 | 28' | 1,173 | 1,534 | 1,877 | 2,069 |
| 16° | 7.98 | 26' | 937 | 1,226 | 1,499 | 1,653 |
| 14° | 7.36 | 23' 11" | 735 | 962 | 1,176 | 1,297 |
| 12° | 6.74 | 21' 11" | 565 | 739 | 903 | 996 |

THROUGHPUT - EXPLAINED

All Telestack throughputs are primarily based on a recommended running angle of 18° , meaning that to achieve the quoted tonnage the conveyor needs to be operated at this angle.

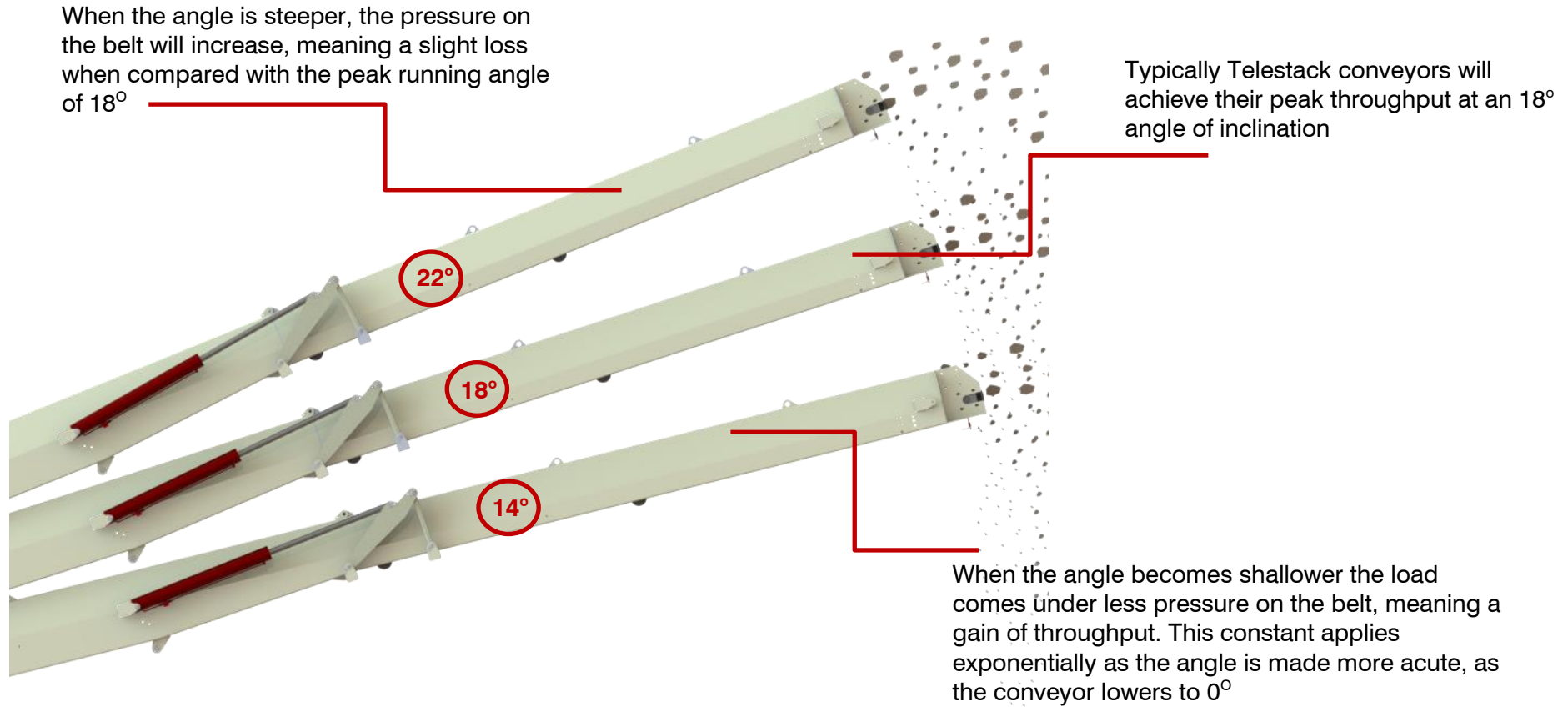

TC 424X - WORKING DIMENSIONS

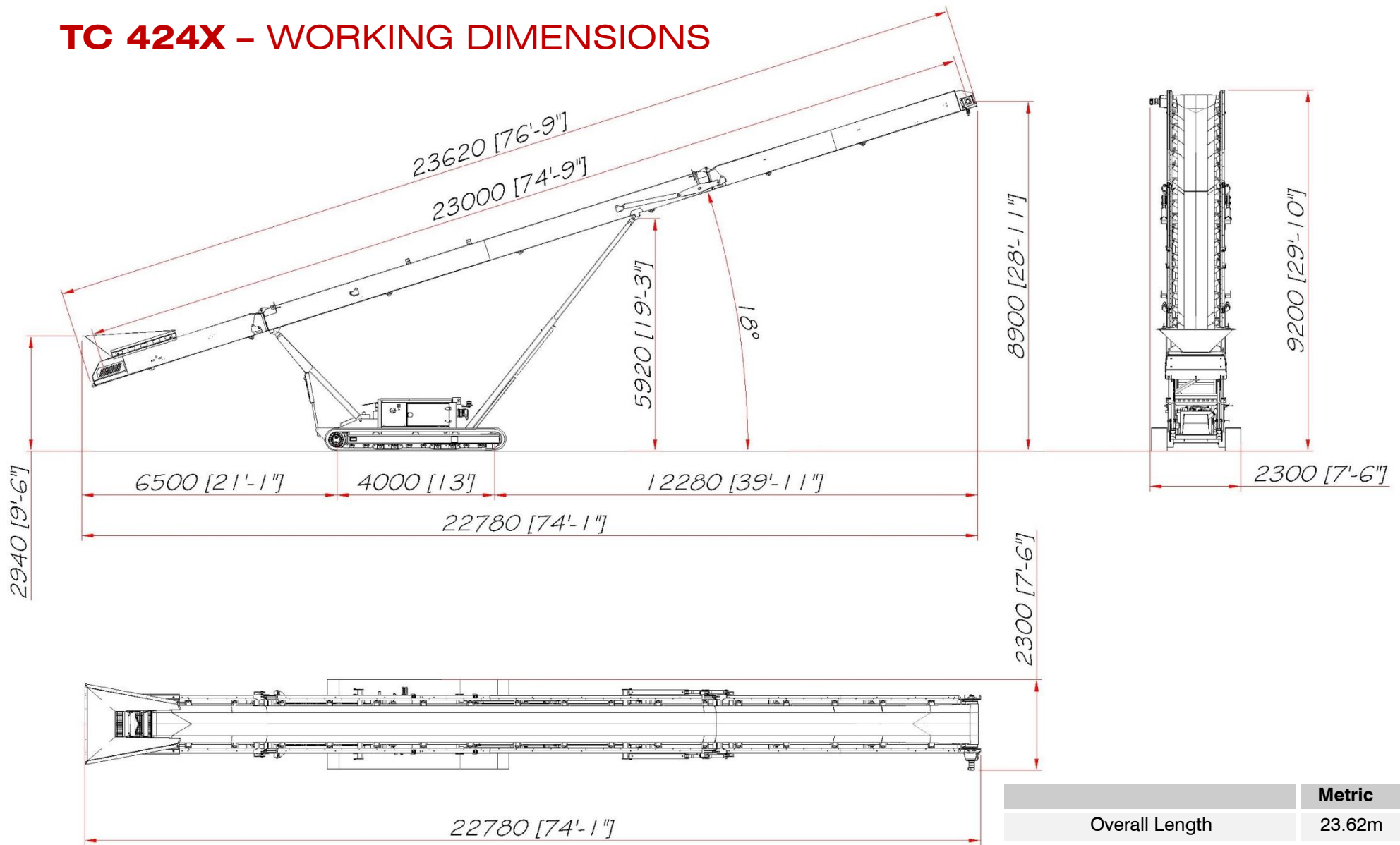

| | Metric | Imperial |
|------------------------------|--------|----------|
| Overall Length | 23.62m | 76' 9" |
| Machine Working Length (18°) | 22.78m | 74' 1" |
| Discharge Height (18°) | 8.9m | 28' 11" |
| Feed in Height (Rear) | 2.94m | 9' 6" |
| Operating Width | 2.3m | 7' 6" |

THE POWER TO MOVE MATERIALS

TC 424X - TRANSPORT DIMENSIONS

1

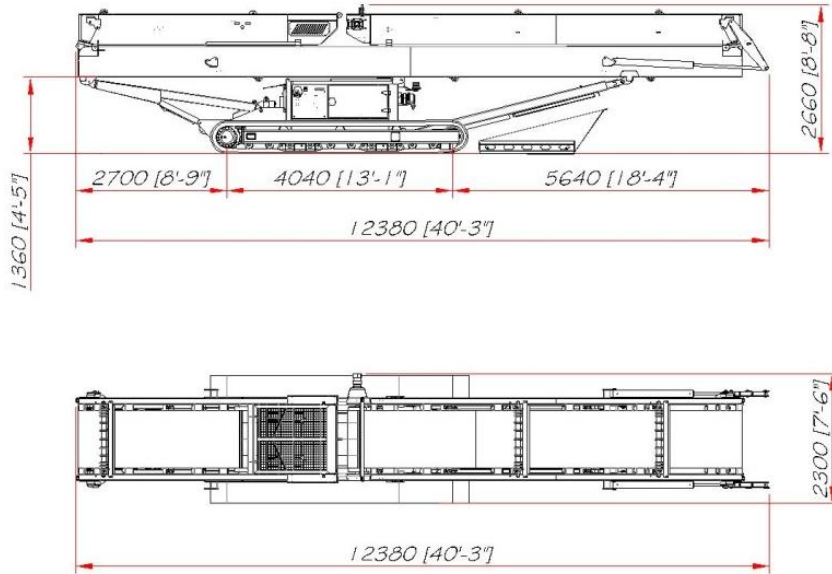

2

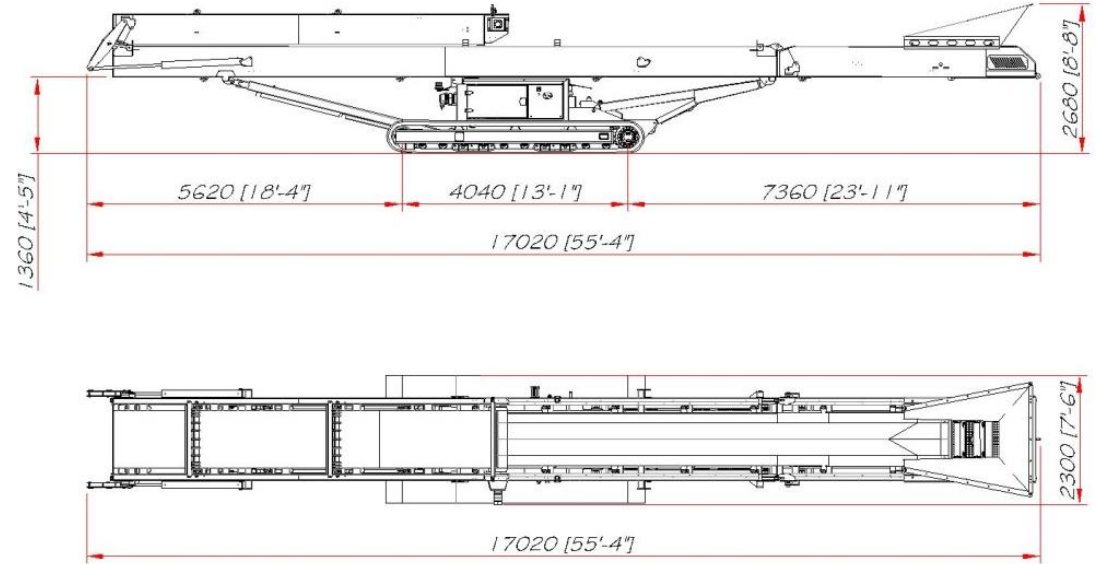

1

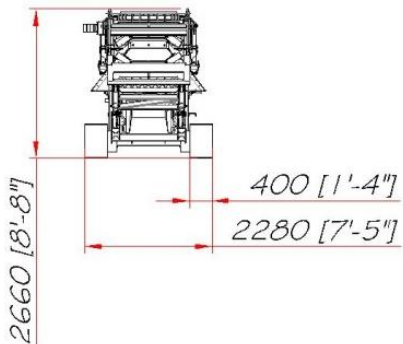

2

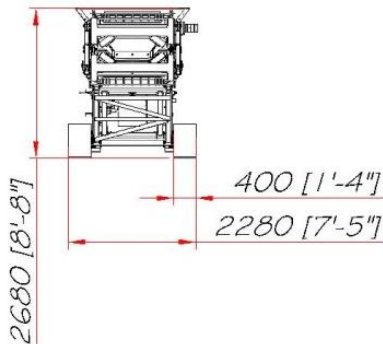

| | Metric | Imperial |
|--|-----------|------------|
| Transport Length (Head & Tail Folded) | 12.38m | 40' 3" |
| Transport Length (Head Folded) | 17.02m | 55' 4" |
| Transport Width | 2.28m | 7' 5" |
| Transport Height (Head & Tail Folded) | 2.66m | 8' 8" |
| Transport Height (Head Folded) | 2.68m | 8' 8" |
| Overall Weight | 11,950 Kg | 26,345 lbs |
| Unit can also be transported in a 40' High cube container. | | |

TC 424X – MACHINE FEATURES

Feedboot

- Tapered feed boot design, with large material target area
- Adjustable rear telescopic for variable feed in height.
- Feed in (Min) - 1.38m (4' 3")
- Feed in (Max) - 2.94m (9' 6")
- Width - 2.0m (6' 8")
- Length – 2.3m (7' 9")
- Steel - 6mm (1/4")
- 102mm (4") Rubber covered impact centre roller with wing rollers



Incline Conveyor

- Heavy duty folded mild steel plate design
- The folded plate design gives an optimum strength to weight ratio
- Hydraulic folding head and manual folding tail section for transport as standard
- Standard 1050mm (42") wide EP 400 3 Ply, 4mm+2mm Belting, ran at 2.14m/s- (421 ft/min)
- 102mm (4") diameter troughing rollers set.
- Wing roller angle adjustable.
- 150mm (6") diameter disc return rollers. Includes profiled steel nip guard as standard
- High torque, direct drive orbital motor. single drive

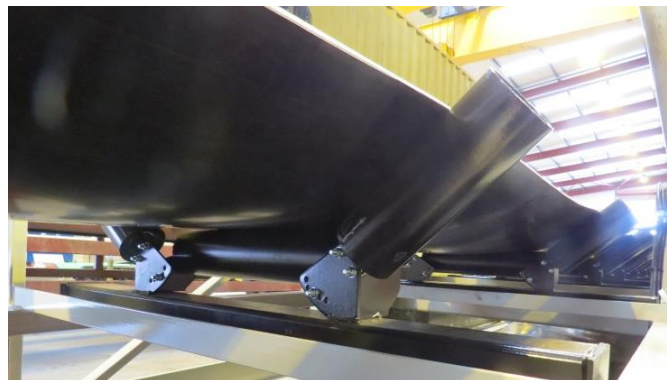

Chassis

- Heavy Duty FL4 Tracks
- Longitudinal centres: 4000mm (13')
- Track shoe width: 400mm (16")
- Drive: Two integral hydraulic motors
- Tensioning: Hydraulic adjuster, grease tension
- Tracking: Push button pendant type (dog lead)
- Speed of tracks: 0.58 kph (0.36 mph)
- Heavy duty structural steel chassis, with integrated webbed plate design for the rear telescopic mountings.
- Large, lockable canopy access doors for ease of operation and maintenance.

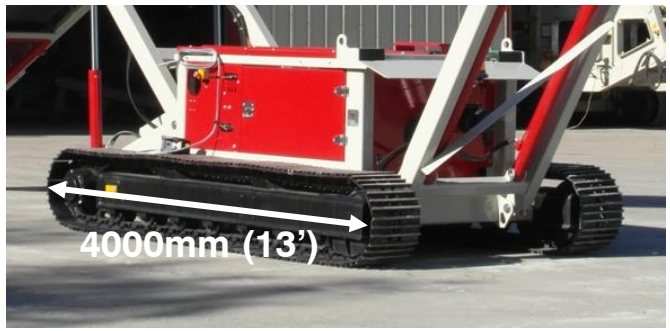

Hydraulics

- Triple pump system
- Easy access for maintenance to all hydraulic components such as pumps, filters, tanks, valves etc
- Steel fabricated hydraulic tank complete with fill level gauge and lockable filler cap.
- Capacity: 250 litre (66 US Gallons)
- Oil type: Grade 32

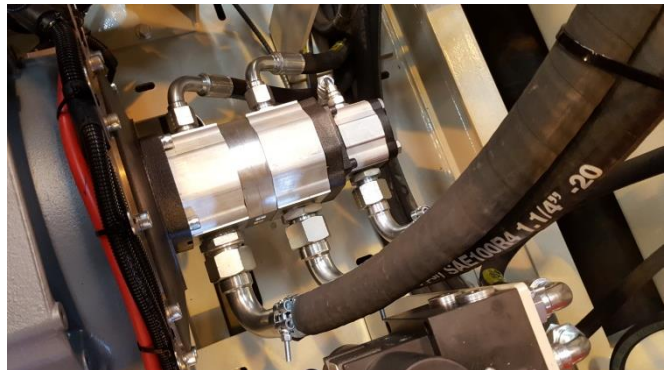

Engine & Control

Standard / EU Stage V

- Deutz TD2.2 L3 Electronic 3 Cylinder, 36.9KW (50HP) @ 2200 RPM

EU Stage USA Tier 4

- Deutz D2.9 L04i, 36.4kW (50Hp) @ 2200 Rpm

EU STAGE V (Upgrade for higher tph)

- Deutz TD2.9 L04i, 50kW (67Hp) @ 2200 Rpm

Unregulated Countries

- CAT Tier 3/Euro IIIA, 2.2, 37kW (50Hp) @ 2200 Rpm
- Deutz L03i, 3 cylinder, 2011, Air cooled, 28.8 kW (38 Hp) @ 2200 rpm

- Start-up system with safety features (fully fused and fault display).
- Engine monitoring and tracking system
- Standard electrical PCB microprocessor technology with led indication.
- Faults are logged on led indicators until resolved.
- LED indicator self test executed every time unit is switched on.
- One place label using standard symbols.
- Full frequency certified CE, FCC, AU and Japanese remotes systems.
- Panel mounted in secure canopy with lockable doors.

Diesel Tank

- Steel fabricated fuel tank complete with fill level gauge and lockable filler cap.
- Capacity: 180 litres (47 US gallons)



TC 424X – OPTIONAL EXTRAS

Bolt in Feedboot Liners

- **Option 1:** Bolt in 6mm (1/4") steel wear liners.
- **Option 2:** Bolt in 6mm (1/4") hardened steel wear liners.
- **Option 3:** Bolt in Rubber Liners

Feedboot, Adjustable Feed Gate

- Adjustable feed gate to control the flow of material from the feedboot.
- With this option a front plate along the feedboot is also necessary which means it must be removed to fold the tail section.

Feedboot, Fall break System

- Bolt in fall break system to stop larger pieces in the material hitting the belt and causing damage to the conveyor.
- With this option a front plate along the feedboot is also necessary which means it must be removed to fold the tail section.

Anti-Roll Back

- 4 x sets of anti roll back fittings can be fitted to the incline conveyor to prevent material from rolling back down the belt when the conveyor is at a steep angle

Conveyor Side Skirting

- Bolt on rubber side skirting up the length of the conveyor to avoid material spillage.

Belt Weigher

- Integrated belt weighing system, with control panel.
- Optional USB data logger.

Dust Suppression System

- Dust suppression system is used with materials that are likely to create a lot of dust.
- The system has dust covers running the full length of the conveyor and a head chute with rubber sock.

Belting Upgrade

- 1050mm (42") 3 ply EP500 x 5 + 1.5mm
- Belt Speed 2.14 m/s- (421 ft/min)

Hydraulic Folding Tail Section

- Hydraulic folding tail section for ease of transportation.
- Feedboot does not need to be removed to fold tail section.

Overband Magnet

- An Overband magnet sits over the belt of the conveyor, removing harmful metallic contaminants from the main material

Dual Power

- An electric motor and control panel can be mounted on the machine to run using electric power. Machine can also run using the diesel engine when required.
 - Diesel engine used to run tracks
 - 30Kw (50hp) Electric motor.
 - Control Panel mounted within the engine canopy.

Pin Telescopic

- Optional front and rear pin telescopic, this will allow more control over the conveyor. Holes in the rear and front arms allow a metal rod to be inserted, restricting the movement of the conveyor.

Basket Guards

- The basket guards are another optional safety feature, they are attached to the underside of the

TC 424X – TRANSPORT INFORMATION

Options

The TC 424X can be transported in a number of ways :

1. Unit on 1 x low loader / Ro Ro (with head section folded over)
2. Unit on 1 x Low Loader / Ro Ro (with head section & tail section folded over)
3. Unit in 1 x Euro Liner (with head section & tail section folded)
4. Unit in 1 x 40' High Cube Container (with head section & tail section folded)
5. Unit in 1 x Euro Liner (with head section folded & feedboot removed)
6. Unit in 1 x 40' High Cube Container (with head section folded & feedboot removed)



Containerisation

1. The Conveyor is transported in a 40'ft High Cube Container (Inside Dimensions Length-12.m, Height-2.597m, Width-2.340m).
2. Conveyor must have head and tail section folded over, or the head section folded and feedboot removed.

On arrival to destination the customer must do the following

1. Enter container and start machine after reading safety instructions
2. Track the unit from the container with the engine on its lowest rev setting.
3. When unit is removed from the container, fold the head section using the hydraulic controls.
4. Finally fold tail section or place feedboot on to tail section using a telescopic handler or similar equipment.

Equipment required for unloading and assembling the TC 424X

A Telescopic Handler or similar equipment to unfold the tail section or to place the feedboot on to the tail section of the unit.



TC 424X - GENERAL ARRANGEMENT

OPERATIONAL - FEEDBOOT RAISED

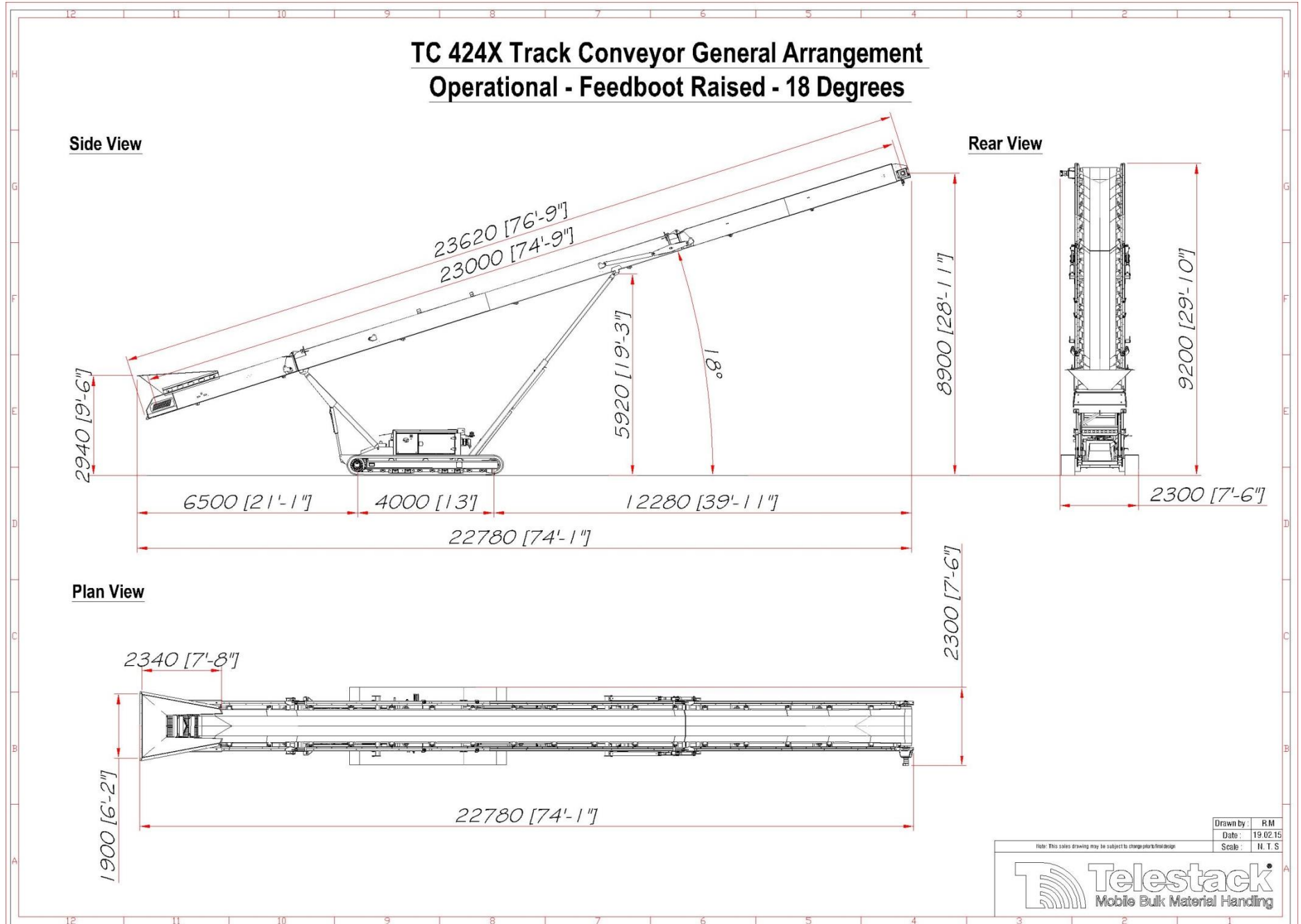

TC 424X – GENERAL ARRANGEMENT

OPERATIONAL – FEEDBOOT LOWERED

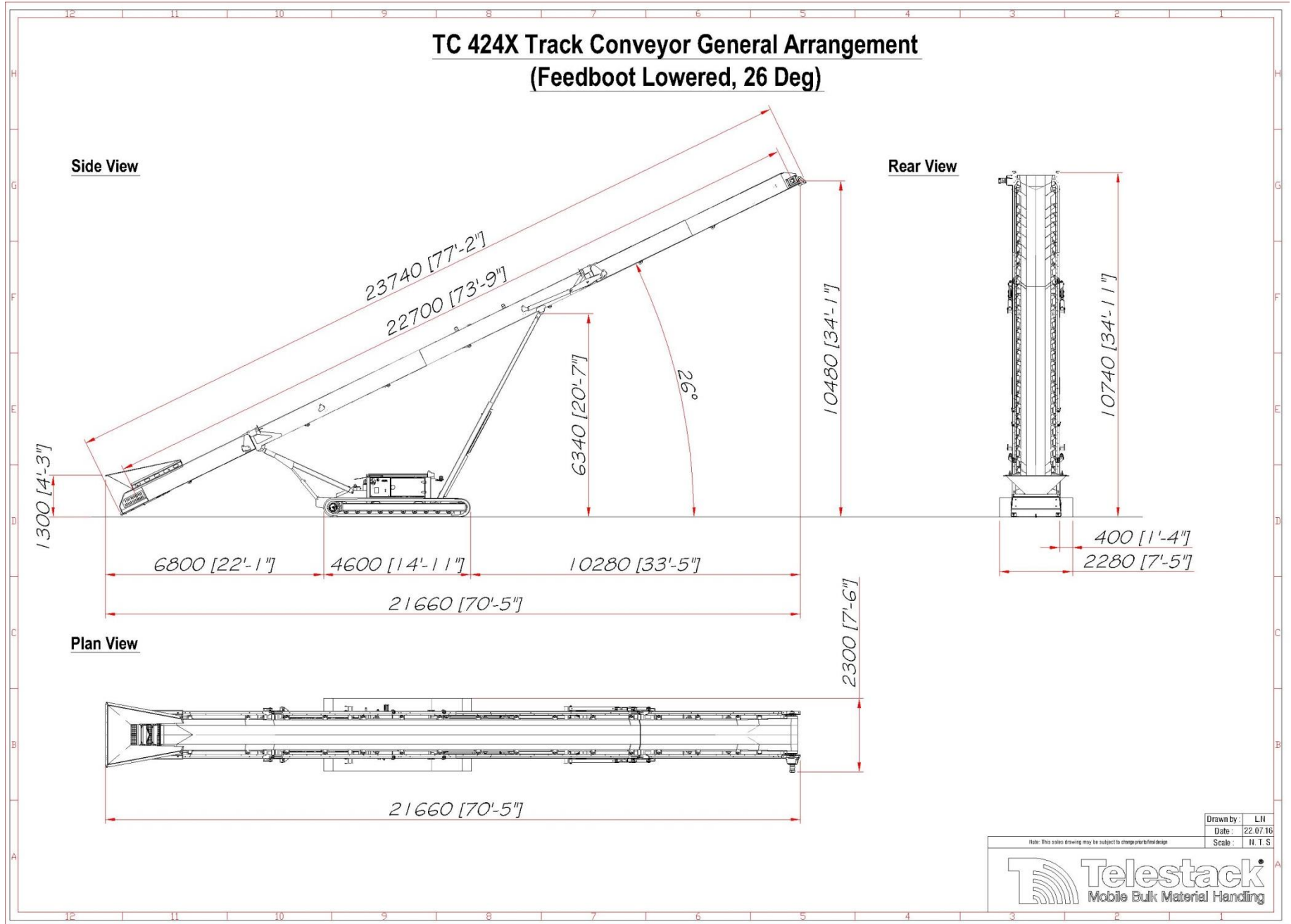

TC 424X - GENERAL ARRANGEMENT

TRANSPORT VIEWS

TC 424X - Track Conveyor (Transport Views)

Head Folded, Tail Not Folded (Feedboot Fitted)

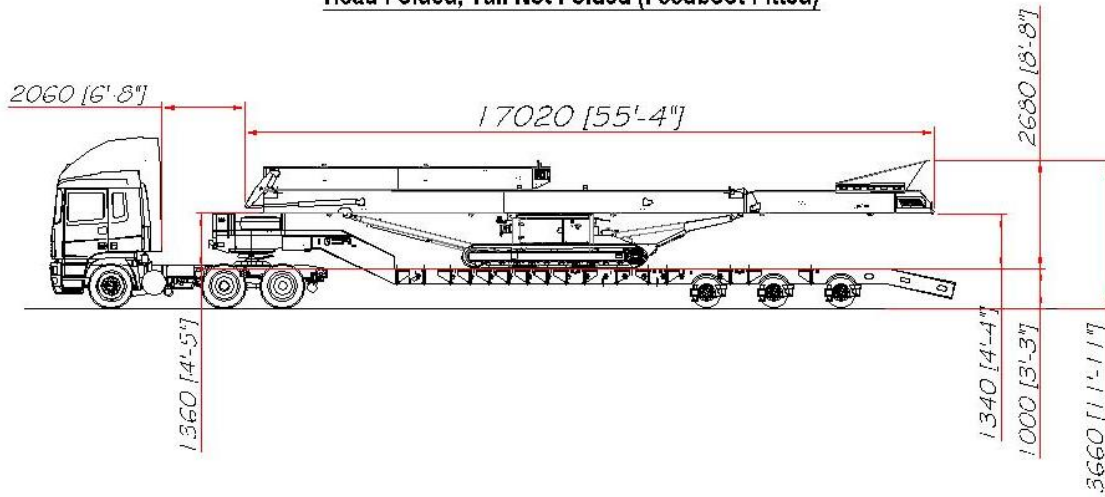

Head and Tail Folded (Feedboot Fitted)

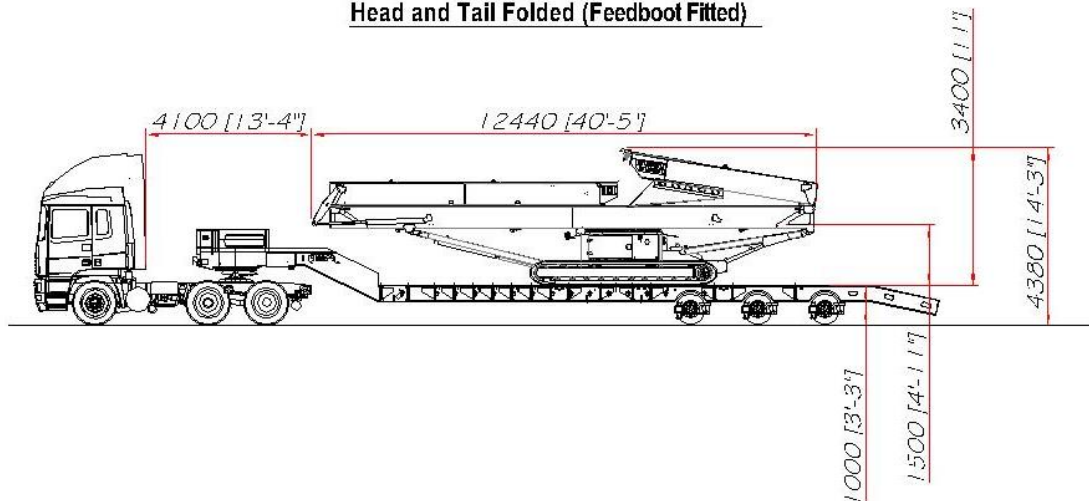

Head and Tail Folded (Feedboot Not Fitted)

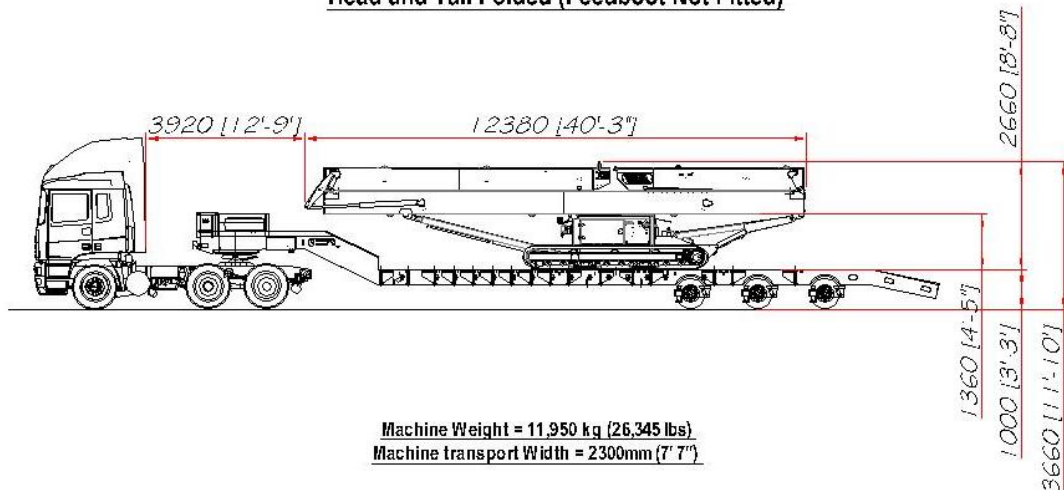

Machine Weight = 11,950 kg (26,345 lbs)
Machine transport Width = 2300mm (7' 7")

| | |
|----------|-----|
| Drawn By | ... |
| Check | ... |
| Scale | 1:1 |

Telestack Limited
Bankmore Way East
Omagh, Co.Tyrone
Northern Ireland
BT79 0NZ

Tel: +44 (0) 2882 251100
Fax: +44 (0) 2882 252211
Web: www.telestack.com
Email: Sales@telestack.com



**THE
POWER
TO MOVE
MATERIALS**

The information in this document is for information only and is subject to change without notice. Telestack assumes no liability resulting from errors or omissions in this specification, or from the use of the information contained herein. Due to the continual product development we reserve the right to change specifications without notice. Any product dimensions and figures given out in this specification are for guidance purposes only. These results will vary depending on product, commodity and application. Some or all of the machines in these pictures may be fitted with optional extras. Telestack is a registered trademark.